

MS-9000: MegaStar Reader

The MS-9000 MegaStar Reader

The MS-9000 MegaStar Reader is intended for installation in proximity applications where an extended read range is required. The reader provides an audible beeper and a multi colored LED to annunciate the reader's status when used on a PXL-250, PXL-100, or IntelliProx.

- Amber - to indicate normal operation awaiting an access event
- Green - to indicate a valid card has been presented or the door has been unlocked for access
- Red - to indicate an invalid card has been presented or the door is in an alarm condition

The MS-9000 MegaStar Reader is housed in a black, weatherproof, shock resistant package. The reader provides optimum performance when mounted at least ten inches away from metal surfaces; read range is reduced if the reader is mounted on or near metal surfaces.

1.0 Specifications

1.1 Dimensions

- 16 inches High x 12 inches Wide x 1.35 inches Deep
- 40.64 cm High x 30.48 cm Wide x 3.43 cm Deep

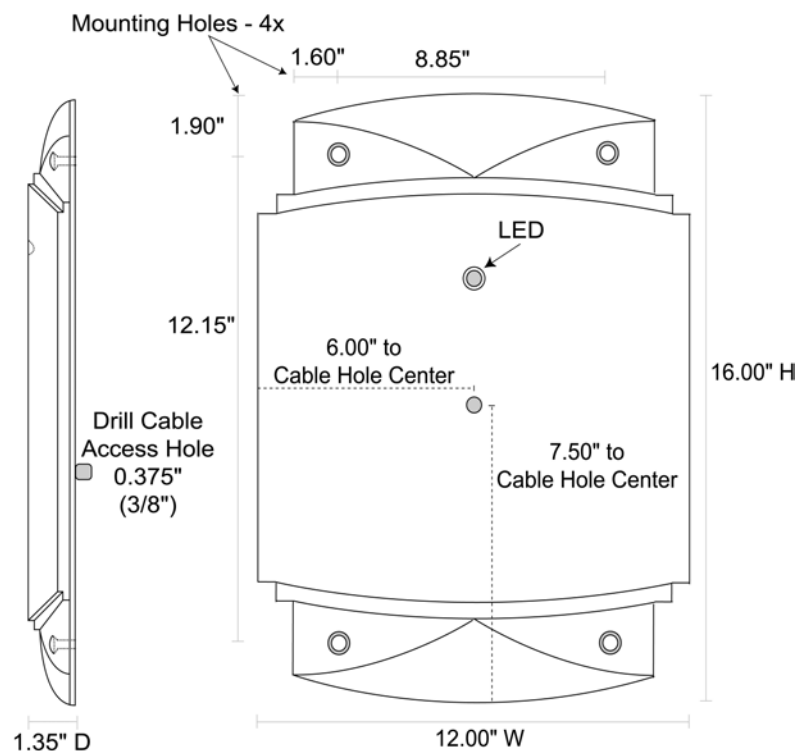

Figure 1: MS-9000 Dimensions



MS-9000: MegaStar Reader

1.2 Operating Voltage

- 12v to 24v DC @ 200 ma

1.3 Cable Specifications

- up to 100 feet using six conductor, shielded, stranded AWG 24 wire
- up to 250 feet using six conductor, shielded, stranded AWG 22 wire
- up to 500 feet using six conductor, shielded, stranded AWG 18 wire

2.0 Mounting Instructions

Five holes need to be drilled to mount the MegaStar Reader (see Figure 1 on page 1). One hole (0.375" – 3/8") accommodates the reader cable. Four holes are for mounting the reader on a wall surface (hole size is dependent upon the size of the mounting screw – a 1/4" screw or bolt is recommended).

For parking or related applications, the MegaStar Reader can be mounted to a metal "goose-neck" stand, provided the mounting surface on the stand is 4 inches x 4 inches or smaller. This size restriction on the stand's mounting surface ensures the metal in the stand does not affect the operation of the Reader. If the stand's mounting surface is greater than 4 inches x 4 inches a mounting plate made of nonmetallic material is required between the stand's mounting surface and the Reader to provide the necessary distance between Reader and metal to ensure optimum read range.

NOTE: Do not mount the reader near sources of Electromagnetic Interference (EMI) such as a computer monitor. EMI degrades a reader's read range.

3.0 Connections

The MegaStar Reader does not require configuration; there are no switches or jumpers to set. The MegaStar Reader is normally connected to a PXL-250, PXL-100, or IntelliProx, but can be connected to an alternative host controller/alarm panel through an IntelliProx used in its Wiegand input device mode. All connections needed to support the reader are made through the reader's cable. Please consult the tables on pages 2 and 3 for specific connection instructions.

MS-9000: MegaStar Reader

3.1 PXL-250 Connections

The "A" reader connects to TB5, pins 1 through 6 (TB5 has a seventh pin, but no connection is made to that pin). The "B" reader connects to TB6, pins 1 through 6 (TB6 has a seventh pin, but no connection is made to that pin).

Connecting to the PXL-250 – TB5 or TB6

Pin #	Function	Wire Color
1	Reader Antenna	Blue
2	Beeper	Green
3	Reader Power	Red
4	Reader Ground	Black
4	Shield	Silver
5	Green LED	Brown
6	Red LED	White
7	no connection	–

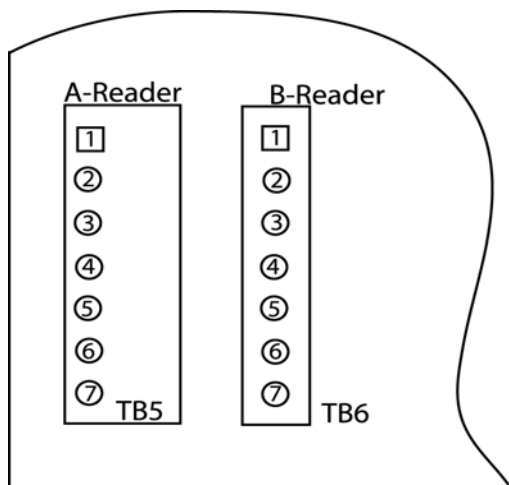

Figure 2: PXL-250 Connections

MS-9000: MegaStar Reader

3.2 Design 5 PXL-100 Connections

The "A" reader connects to TB2, pins 14 through 19. The "B" reader connects to TB3, pins 20 through 25.

Connecting to the PXL-100 – TB2

Pin #	Function	Wire Color
14	Green LED	Brown
15	Beeper	Green
16	Reader Power	Red
17	Reader Ground	Black
17	Shield	Silver
18	Reader Antenna	Blue
19	Red LED	White

Connecting to the PXL-100 – TB3

Pin #	Function	Wire Color
20	Green LED	Brown
21	Beeper	Green
22	Reader Power	Red
23	Reader Ground	Black
23	Shield	Silver
24	Reader Antenna	Blue
25	Red LED	White

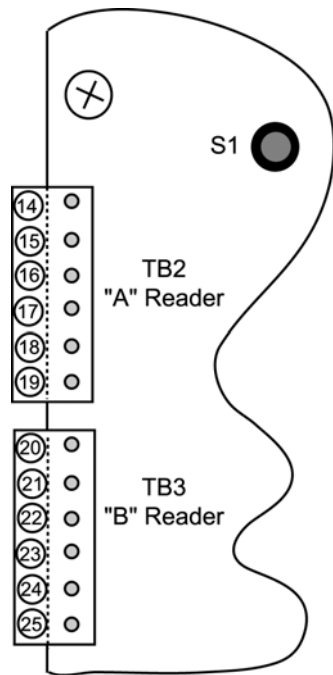

Figure 3: Design 5 PXL-100 Connections

NOTE: Please contact customer support at Keri Systems for information regarding connecting a Reader to a Design 4 PXL-100. A Design 4 PXL-100 can be identified by the location of its power connection made at the middle of the left edge of the printed circuit board.

MS-9000: MegaStar Reader

3.3 IntelliProx Connections

The reader is connected to TB1, pins 1 through 6.

Connecting to the IntelliProx – TB1

Pin #	Function	Wire Color
1	Reader Antenna	Blue
2	Beeper	Green
3	Green LED	Brown
4	Red LED	White
5	Reader Power	Red
6	Reader Ground	Black
6	Shield	Silver

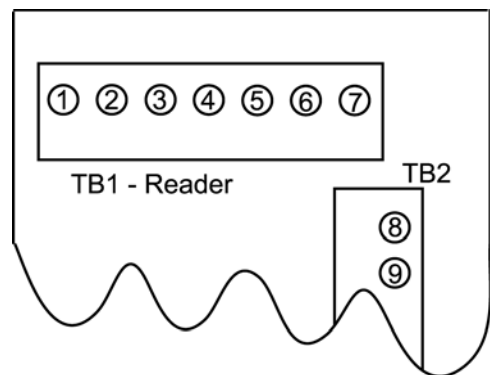

Figure 4: IntelliProx Connections



MS-9000: MegaStar Reader

3.4 24 VDC Power Option

Instead of the 12 VDC power provided by the controller or IntelliProx unit, the MegaStar Reader can be powered by a 24 VDC linear, regulated power supply. The advantage to the 24 VDC supply is that the read range is increased by approximately 20%. Perform the following steps to use the 24 VDC power option.

1. Disconnect the power and ground leads from the controller or IntelliProx unit.
2. Connect the positive lead from the 24 VDC supply to the Red lead on the Reader cable.
3. Connect the negative lead from the 24 VDC supply to the Black lead on the Reader cable.
4. Connect the ground lead from the 24 VDC supply to the power ground on the controller or IntelliProx unit.
 - TB2, pin 2 on the PXL-250 (see Figure 5)
 - TB4, pin 27 on the PXL-100
 - TB2, pin 13 on the IntelliProx (see Figure 6 on page 7)

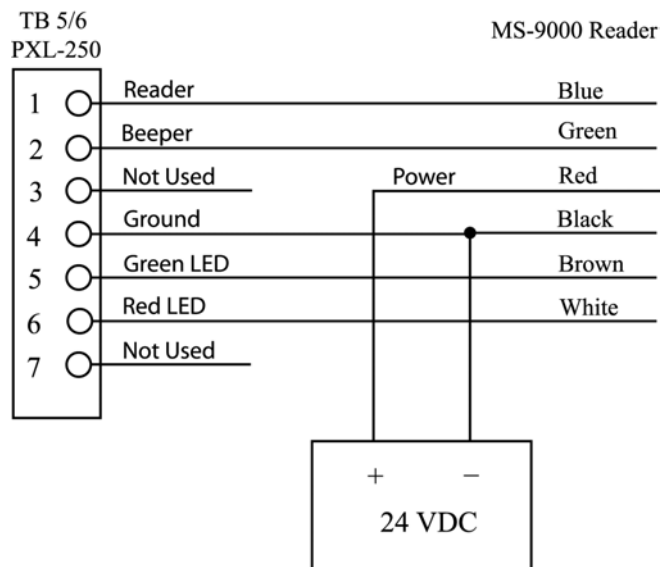

Figure 5: PXL-250 Connection to 24 VDC Power

MS-9000: MegaStar Reader

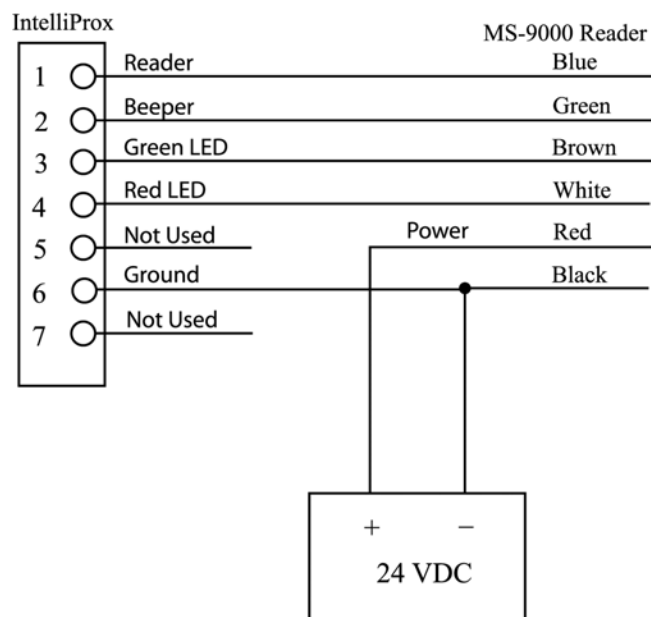

Figure 6: IntelliProx Connection to 24 VDC Power

MS-9000: MegaStar Reader

4.0 Installation Verification

The following information applies to an installation with a Keri Systems controller or IntelliProx unit. When used with an alternative host controller/alarm panel through an IntelliProx used in its Wiegand input device mode, the actions of the reader's LED and beeper are controlled by the alternative host controller/alarm panel and might not match those of a Keri Systems controller.

The reader's power is provided by the controller, so the reader is powered on when the controller is powered on. The reader's normal state is to display a constantly on Amber LED as it waits for a card or tag to be presented.

To verify the reader is functioning properly, pass a Keri Proximity Card or a Keri Key Tag within a few inches of the reader. The reader will beep and either the Green or Red LED will flash (depending upon whether or not the card/tag has been enrolled at the controller) and then return to steady Amber.

To verify the reader's read range, hold a Keri Proximity Card or a Keri Key Tag parallel to the reader, about 3 feet away and slowly draw the Card/Tag in toward the reader. Note the distance when the reader recognizes the card. Refer to the table below for the MegaStar reader's read range. This range will vary depending upon the installation conditions, the material on which the reader is mounted, whether it is a card or a tag being read, and the age of the card or tag. Due to the physical size difference between cards and tags, tags provide approximately 50% less read range than cards.

Read Range ¹		
	12 VDC	24 VDC
Cards	14.5 inches	18.5 inches
Tags	4.5 inches	9.5 inches

1. Depending upon the installation conditions, the material on which the reader is mounted, and the age of the card or tag, read range may increase to more than is shown above.

Refer to the [Troubleshooting the Reader Installation](#) section if the reader is not functioning properly.



MS-9000: MegaStar Reader

5.0 Troubleshooting the Reader Installation

Problem	Probable Cause	Corrective Action
The reader does not recognize a card/tag (no beep, no LED flash).	1. One or more of the reader's wiring connections are incorrect.	<ul style="list-style-type: none"> Power down the controller and verify the wiring connections are correct for the reader/controller combination per the instructions provided in the Connections section on pages 2 and 3.
	2. The reader is not receiving proper power from the controller.	<ul style="list-style-type: none"> If powering the reader at 12 volts, verify the voltage supplied by the controller is at 12 VDC +/- 2 V. If powering the reader at 24 volts, verify the voltage supplied to the reader is at 24 VDC +/- 2 V.
	3. The reader is mounted too close to a device that radiates electromagnetic interference.	<ul style="list-style-type: none"> Devices such as computer monitors radiate electromagnetic interference that affects read range. When possible, relocate either the reader or the device to provide a greater distance between the two.
	4. A jumper is not set correctly on the controller.	<ul style="list-style-type: none"> <u>For a PXL-250</u>: Verify there is a jumper across pins 1 and 2 of JP4 (refer to the Technical Reference manual for more information - Keri p/n 01836-001). <u>For a PXL-100</u>: If the controllers are using TAP™ software, verify JP1 on the controller and the jumper on the Receiver card¹ are installed across both jumper pins. If the controllers are using Doors™ software, verify JP¹ on the controller and the Receiver card¹ are not installed across both pins (typically the jumper will be installed onto one of the pins to keep it available). <u>For an IntelliProx</u>: Verify there is not a jumper across pins 1 and 2 of JP1 (typically the jumper can be installed onto one of the pins to keep it available).
	– continued next page –	

1. The receiver board's jumper is on the underside of the board. Gently pull the receiver board away from the controller, verify the jumper setting is correct per your application, carefully align the connectors on the receiver board with the pins on the controller, and gently push the receiver board back into place.



MS-9000: MegaStar Reader

Problem	Probable Cause	Corrective Action
	5. You are using an incorrect type of card.	<ul style="list-style-type: none"> Make sure you are using an access card that is compatible with the reader.
	6. The reader is unable to read the card.	<ul style="list-style-type: none"> Verify there is nothing that can interfere between the reader and the access card.
The reader has a short read range.	1. The reader's controller is not properly grounded.	<ul style="list-style-type: none"> Ensure there is a quality earth ground connection made to the controller. Refer to the controller's documentation for specific information regarding the earth ground connection.
	2. The shield wire for the reader's cable has opened somewhere between the reader and the controller.	<ul style="list-style-type: none"> Verify the shield line from the controller to the reader is one continuous, connected line. Refer to the controller's installation documentation and verify the shield line is correctly connected to the controller.
	3. The reader is mounted too close to a metallic object.	<ul style="list-style-type: none"> Remove the reader from its mounting surface and ensure there is no metal on the mounting surface within 10 inches of the reader.
	4. The reader is mounted too close to a device that radiates electromagnetic interference.	<ul style="list-style-type: none"> Devices such as computer monitors and gate safety loop detectors radiate electromagnetic interference that affects read range. When possible, relocate either the reader or the device to provide a greater distance between the two.
	5. The controller is mounted too close to a device that radiates electromagnetic interference.	<ul style="list-style-type: none"> Devices such as computer monitors and gate safety loop detectors radiate electromagnetic interference that affects read range. When possible, relocate either the controller or the device to provide a greater distance between the two.
	6. The reader is powered by a switching power supply.	<ul style="list-style-type: none"> Switching power supplies are EMI sources. Change to a linear, regulated power supply.